

NEWSLETTER

Volume 18 No 4
June 2005

Application of Performance Based Methods to the Seismic Assessment of Existing Nuclear Facilities

Stewart Gallocher addresses some of the problems associated with retrospective seismic qualification.

Abstract

Seismic qualification of existing nuclear facilities is often problematic. Although designed to satisfy (non-seismic) codes of practice, current at the time of construction, they are obviously unable to comply retrospectively with the prescriptive capacity design procedures incorporated in modern seismic standards. Consequently, whilst satisfying an essentially elastic design basis may be achievable at a certain level, demonstration of an adequate margin beyond this needs a more fundamental approach based on the principles of mechanics and a full understanding of the structural behaviour linked to detailing. This paper discusses some of the techniques currently available and provides an example of the application to a safety related nuclear structure.

Introduction

The current approach to the design of nuclear facilities in the existing UK regulatory regime is non-prescriptive, however it is this author's view that best practice in relation to the design of new safety critical concrete nuclear facilities should generally and where appropriate adhere to the requirements set down in the US

standards ASCE 4-98^[1] for analysis and ACI 349-01^[2] (refer to Figure 1) for the design. Adoption of the latter document ensures that 'structural integrity is maintained in the unlikely event of an earthquake beyond the design basis Safe Shutdown Earthquake or other unforeseen circumstances' by providing a series of requirements for components such as beams, columns, walls and joints. These rules, similar to those incorporated in other non-nuclear building standards such as ACI 318-02^[3], are prescriptive and used in lieu of requiring explicit calculation for determining the capacity in critical regions. The main differences between the two standards being the mandatory requirement to apply the Chapter 21 special detailing rules in ACI 349, irrespective of the level of the site specific seismic hazard, and the need for an "essentially elastic design" to be adopted under the Design Basis Event (DBE). Due to the robustness of the approach and the adoption of the special detailing rules, a wide margin against collapse is anticipated and therefore it is not generally required in a UK context to consider specific levels of hazards beyond the Design Basis Events (DBE) when adhering to this standard.

Contents

Page 1	Application of Performance Based Methods to the Seismic Assessment of Existing Nuclear Facilities
Page 7	What You See Is What You Get – Or Is It?
Page 11	Bob Park – A Personal Note
Page 12	Notable Earthquakes January - June 2005
Page 12	Forthcoming Events

Although the design of new nuclear facilities can be undertaken with some certainty in relation to achieving the desired performance, for the assessment of existing facilities the engineer is often presented with a range of structural systems with individual components that possess inherent design deficiencies when

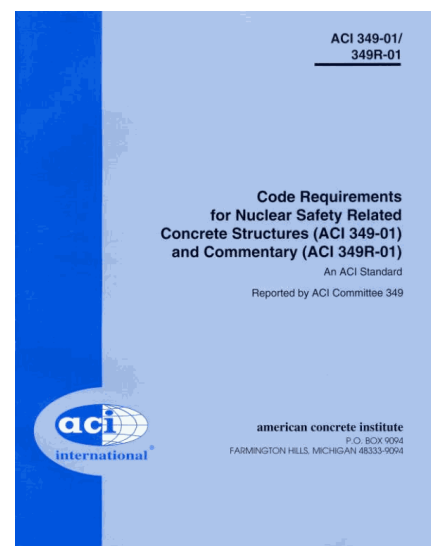

Figure 1 Prescriptive Design Standard

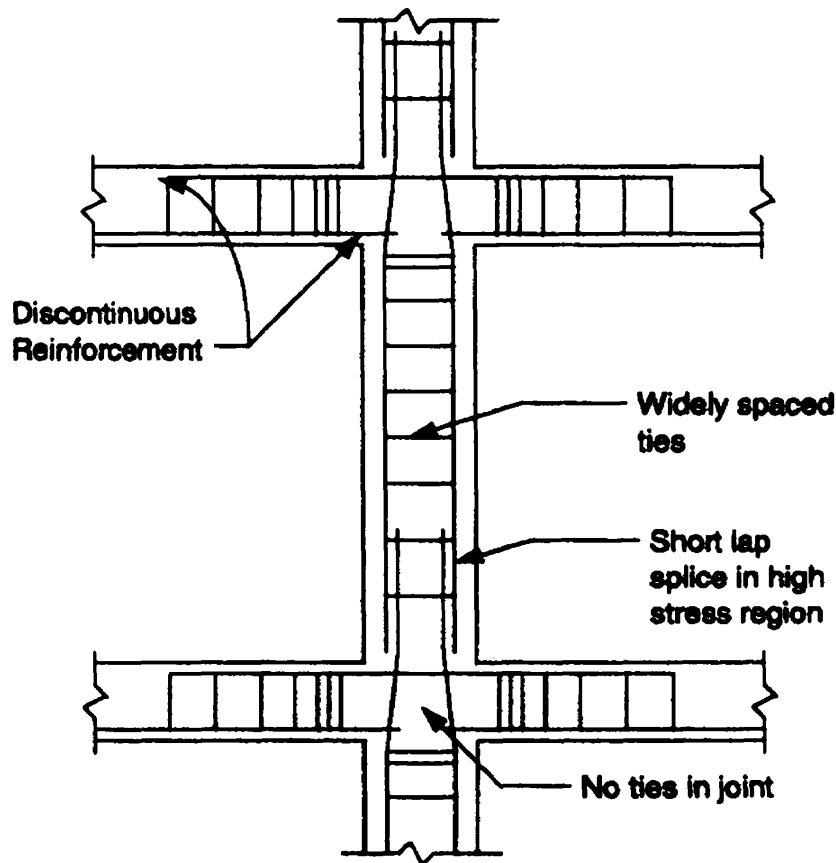

Figure 2 Typical RC Frame Detailing Deficiencies (ATC-40)

assessed against a modern nuclear concrete (or seismic) standard. In many circumstances the reinforced concrete (RC) structures needing to be assessed for seismic withstand will have been designed to historic UK codes of practice that have no specific seismic provisions. This presents the engineer with a range of deficiencies that normally relate to inadequate building configuration and poor structural detailing of the individual components. These component deficiencies, not permitted in modern seismic codes, often include poor details such as widely spaced transverse reinforcement, main reinforcement lap splices in the plastic hinge zones of beams and columns, discontinuous reinforcement in beams at joint locations and no ties in the joints themselves (refer to Figure 2). Consequently, whilst satisfying an essentially elastic design basis may be achievable at a certain seismic level, demonstrating an

adequate margin beyond this needs a more fundamental approach based on a full understanding of the structural behaviour linked to detailing. In addition to specific items relating to the rebar details some conceptual deficiencies relating to the building configuration may also be present. However, these may be unavoidable due to the function and operation of the nuclear plant.

So what options does the engineer have in relation to the seismic substantiation of existing facilities and what analysis methodologies does he have at his disposal? Some of the potential options that have been applied to the design and assessment of existing building are discussed below.

'Essentially' elastic behaviour at the DBE

In recent years there has been a trend towards the use of 'essentially' elastic

behaviour at the DBE for all structures irrespective of function or risks. This may be unnecessarily conservative for the assessment of existing (or the design of new) facilities where the consequences that are directly linked to the inventory may be low. For instance, requiring an essentially elastic performance of a building frame that is required not to collapse onto safety critical components would be considered conservative, since some localised damage may be permitted without affecting the safety critical plant.

Conversely, a tank containing hazardous waste designed 'essentially' elastically to code based acceptance criteria would perhaps be appropriately designed if exhibiting a near elastic response. One advantage is that this option does provide some confidence that the response of the structure is fairly predictable up to the DBE with no

excursions into the non-linear zone which is of some importance when considering existing structures detailed to non-seismic or historic UK codes. Another benefit is the ease of generating secondary response spectra for the design of secondary structures such as plant and other mechanical and electrical equipment. However, the difficulty with this approach, apart from the potential gross conservatism at the DBE, is at the margins where consideration needs to be given ideally to achieving 'gradual and detectable' behaviour beyond the design basis, or less satisfactorily through significant overstrength in the design. In many cases the engineer may find it difficult to demonstrate an absence of brittle cliff-edge effects that can undermine confidence in the response surrounding the DBE itself.

Limited ductility at the DBE

It is important to realise that there is no explicit reason under the UK regulatory framework for nuclear designs to be undertaken to achieve an essentially elastic performance at the DBE. In many circumstances some limited ductility and damage would be permissible without compromising the performance of the building system or the safety functional requirements. Indeed guidance is available and has been developed from various sources such as NUREG-CR1161^[4]. However, one of the drawbacks with this and other similar approaches is that they are all forced-based approaches with the ductility factor largely based on work undertaken by researchers such as Newmark and Blume in the 1970s. The main drawback with this work is that the predicted inelastic structural response is based on an elastic analysis of the building with the ductility chosen based on the experience of other similar types of building. Although the permissible values adopted for application in the nuclear industry are deemed to be suitably conservative the ductility is assigned at the system level and cannot be correlated against the individual component ductilities i.e. the displacement demands placed on

beams and columns within an existing building cannot be calculated.

In addition to the above limitations, the reductions in design forces developed tend to be fairly small due to the predominance of fairly inflexible squat structural systems that form the main stock of nuclear industry structures. Also, the displacements are calculated through elastic analysis and need to be modified to account for increases resulting from inelastic behaviour. In conclusion, any application of this approach to existing building remains a highly subjective exercise with little understanding obtained of the building performance at or beyond the DBE.

Performance based assessment

The traditional methods (i.e. essentially elastic and limited ductility at the DBE) discussed above highlight techniques where the performance that can be anticipated is not explicitly related to the building performance but generally to some prescriptive code acceptance criteria. The result of these assessments can lead to unnecessary retrofit with large associated costs and most worryingly a lack of understanding and misinterpretation of building deficiencies.

The main alternative to the traditional methods comes from the growing trend towards performance based design (PBD). These methods depend on the development of an improved understanding of the building performance generally by utilising inelastic methods without the need for the prescriptive strength and detailing design approaches of modern seismic standards. They can potentially reduce the costs of upgrading existing buildings by creating a greater understanding of the building performance into the inelastic range. In addition, by having this improved understanding the engineer can present the performance of the building in terms that can be easily understood by the various facility stakeholders thereby creating a greater appreciation of the

building performance and clarity in the reported outcomes. Many of the available approaches were developed in the wake of the Northridge Earthquake of January 1994, however these techniques appear to be a good fit with the safety objectives required by the nuclear industry.

In the PBD approach the performance has two essential parts, namely a damage state and a level of hazard with the most recent pre-standard FEMA 356^[5] incorporating and improving upon many of the techniques that were developed in documents such as ATC-40^[6] and FEMA 273^[7]. This document describes the evaluation process and sets down a basic (non-nuclear) safety objective (BSO) that achieves the dual rehabilitation goals of:

1. Life Safety under Level 1 Earthquake Hazard (10%/50yr – Mean Return Period 475yr), and
2. Collapse Prevention for Level 2 Earthquake Hazard (2%/50yr – Mean Return Period 2,475yr)

However, the standard does allow for enhanced rehabilitation objectives that exceed those associated with the BSO for either larger earthquake hazard levels or building performance levels or a combination of the two that might be anticipated in the rehabilitation of safety critical buildings such as those found at nuclear sites.

The target building performance levels consist of a combination of the structural performance level and non-structural performance. The structural performance is generally selected from four discrete structural performance levels - collapse prevention, life safety, immediate occupancy and operational.

For the non-structural components items are selected from five discrete performance levels, consisting of operational, immediate occupancy, life safety, hazards reduced and not considered.

Component	Deformation-Controlled Action	Force-Controlled Action
Moment Frames • Beams • Columns • Joints	Moment (M) M --	Shear (V) Axial load (P), V V ¹
Shear Walls	M, V	P
Braced Frames • Braces • Beams • Columns • Shear Link	P -- -- V	-- P P P, M
Connections	--	P, V, M

1. Shear may be a deformation-controlled action in steel moment frame construction.

Table 1 Deformation and Force controlled actions (FEMA 356)

The approach set down in FEMA 356 recognises that all elements including non-structural components contribute to the building's overall stiffness, mass and damping and therefore its response to earthquake ground motion. However, it is also recognised that not all components contribute to the structure's ability to resist the forces and displacements generated. A further designation is therefore prescribed to primary components that 'provide the capacity of the structure to resist collapse' and secondary components that do 'not contribute significantly or reliably in resisting earthquake effects'.

In addition to the above, all actions are classified as either deformation controlled or force controlled using component forces versus deformation curves. Typical examples of force controlled and deformation controlled actions are given in Table 1 taken from FEMA 356. The effect of this classification system means that expected strengths are utilised for deformation controlled (ductile) actions and lower bound strength are adopted when evaluating the behaviour of forced controlled (brittle) actions.

There are a range of analysis options set down in FEMA 356 that can be performed using the linear static procedure (LSP), linear dynamic procedure (LDP), non-linear static procedure (NSP), or non-linear dynamic procedure. The NSP procedure offers significant benefit over linear elastic procedures and is implemented by applying lateral loads to the mathematical model in proportion to the distribution of inertial forces in the plane of each floor diaphragm. The structural model is then pushed using displacement or force control until a target displacement, considered to represent the maximum displacement likely to be experienced during the earthquake is reached. The approach taken in FEMA 356 largely follows the Displacement Coefficient Method of FEMA 273 however alternative methods such as the Capacity Spectrum Method (CSM) of ATC-40 are also permissible.

For force-controlled actions the checking is against forces only with the objective to demonstrate that the component force demands (say the axial loads in the columns) are less than the component capacities. For deformation controlled actions the

checking is for deformation only and the objective is to demonstrate that component deformations (say beam plastic rotations) are less than component capacities for the performance levels under consideration.

Case study – 3-5 Berths HMNB Clyde

An example of the application of the NSP procedure to an existing UK Nuclear structure was undertaken by Halcrow Group Ltd when determining the performance of the 3-5 Berth Jetties at Faslane undertaken for the Naval Base Design Authority at HMNB Clyde.

Based on an initial elastic response spectrum analysis, it was predicted that the jetty structure would undergo significant nonlinear response in the transverse direction particularly during an event beyond the design basis. The use of an analysis procedure that could adequately capture this behaviour was required and therefore the CSM, which forms the basis of ATC-40, was chosen for this study. This method, which is a displacement-based evaluation procedure, was considered a more

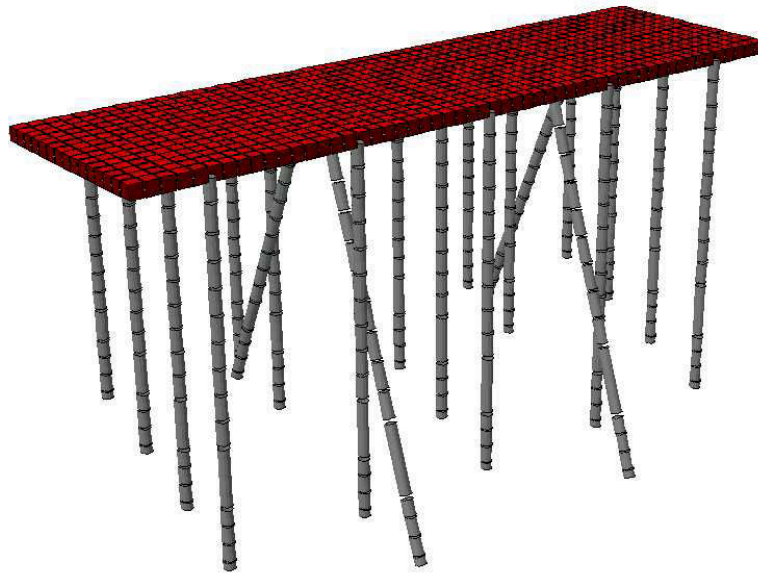

Figure 3: SAP2000 model of Jetty Structure

appropriate method than the traditional force-based procedures for capacity evaluation of ductile structures.

The CSM traditionally presents capacity and demand curves together in an acceleration-displacement response spectrum (ADRS) diagram as shown in Figure 4. The demand curves are plotted in an acceleration-

displacement format. Capacity curves must also be presented in this format and so base shear versus deck displacement relationships developed from nonlinear static (pushover) analysis must first be transformed into the spectral format. Included in the ADRS diagram of Figure 4 are lines radiating from the origin; these lines represent structural period. These lines are useful in

determining the secant structural period at any point on the capacity curve. The point at which the demand and capacity curves intersect is often termed the performance point. The demand curve is generally modified to account for inelastic action in the structure. Reduction factors, normally interpreted as increased damping (approximating hysteretic energy dissipation as equivalent viscous

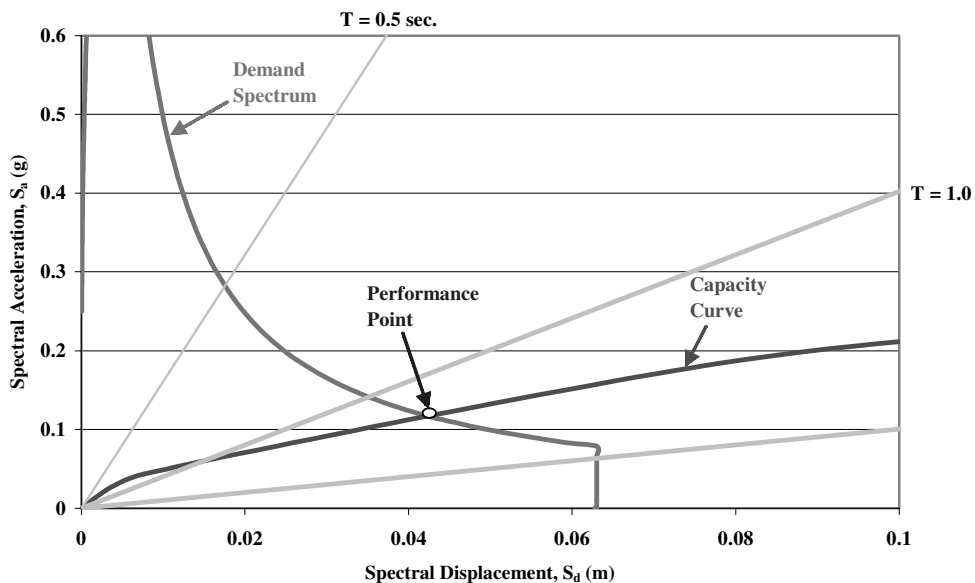

Figure 4: ADRS Spectra

damping), are used to reduce the 5%-damped spectral ordinates. These have not been used in the study and the inelastic demand curves are therefore not shown.

Within the SAP2000^[8] model (see Figure 3), the deck was modelled using elastic four-node thick shell elements while the piles were modelled using 3-D beam-column elements.

To capture the nonlinear behaviour of the supporting structure, axial and moment hinges were implemented with careful consideration given to modelling the expected behaviour of the piles. The plastic hinges assigned to the piles were capable of capturing three different nonlinearities. At the toe of the raker piles, a compression-only axial hinge was used to model lift-off and prevent the formation of tensile forces in the piles. Buckling of the raker piles in compression was considered by modelling an axial hinge in the centre of the piles to prevent the pile compression force from exceeding the buckling capacity of the pile. Finally, hinges were inserted at the top of the piles to capture plastic deformations at the top due to rotation. Force-deformation or moment-rotation relationships of the hinges generally followed the recommendations of FEMA 356.

The CSM proved to be an effective tool for the analysis of this structural type which may undergo nonlinear and/or inelastic behaviour. In addition non-linear pushover analysis gives insight into failure modes and structural characteristics in the non-linear range of behaviour, which cannot be so readily gained by traditional methods or often by more sophisticated non-linear time history analysis. Although traditional methods of analysis predicted poor performance of the jetty and its supporting piles under high levels of earthquake shaking, assessment of the jetty using the CSM showed the opposite, namely, acceptable performance at these levels of shaking.

Conclusions

The advantage of performance based methods is that it is non-prescriptive in terms of the design strength and detailing, allowing the system response to be significantly enhanced by strengthening at a component level based on analysis results taken directly from the mathematical model. This represents a significant advance on conventional methods that can lead to unrealistic or inadequate assessment of buildings without the identification of the true failure modes.

In order for the widespread adoption of the methods detailed in FEMA 356 and other associated publications there needs to be a general realisation within the UK Nuclear Industry that these techniques represent a significant step forward in evaluating the building performance and producing cost-effective strengthening solutions. Whilst some concerns exist relating to the reliability associated with the NSP in certain circumstances (due to the loss of accuracy associated with single mode simplified dynamic procedures), the main attraction remains that the engineer gains an increased insight into the structural behaviour and the load paths with an ability to significantly reduced retrofit costs. This engineering insight is a significant advantage over more rigorous non-linear time history analysis in which structural actions and load paths are hidden in a welter of data.

References

- 1 American Society of Civil Engineers, Seismic Analysis of Safety Related Nuclear Structures and Commentary, ASCE 4-98, 1998.
- 2 ACI 349-01. Code Requirements for Nuclear Safety Concrete Structures' ACI Committee 349, American Concrete Institute, 2001

- 3 ACI 318-02. Building Code Requirements for Reinforced Concrete. Detroit, Michigan. American Concrete Institute, 2002.
- 4 N U R E G / C R - 1 1 6 1 . Recommended Revisions to Nuclear Regulatory Commission Seismic Design Criteria. U.S. Nuclear Regulatory Commission. December 1979.
- 5 FEMA 356. Prestandard and Commentary for the Seismic Rehabilitation of Buildings. Washington , D.C., ASCE for the Federal Emergency Management Agency.
- 6 ATC 40, Seismic Evaluation and Retrofit of Concrete Buildings, prepared by the Applied Technology Council (Report No. ATC-40), Redwood City, California for the Seismic Safety Commission (Report No. SSC 96-01)
- 7 FEMA 273, 1997, NEHRP Guidelines for the Seismic Rehabilitation of Buildings, prepared by the Building Seismic Safety Council for the Federal Emergency Management Agency, 1997, Washington DC
- 8 Computers and Structures Inc., "SAP2000", Nonlinear Version 7.42, Berkeley, California

What You See Is What You Get – Or Is It?

A sideways look at correlation of seismic time histories, by **Ian Morris** of Nexia Solutions.

To design a structure to withstand earthquake shaking, a fundamental requirement is to have a description of the seismic loading to be withstood. Static accelerations, response spectra (typically plots of acceleration against structure frequency) and time histories of motion are the most commonly used descriptions of seismic loading. To be suitable as a design basis, these need to fit for the purpose and guidance on how to measure their fitness is available from a number of references. In the UK, ASCE 4-98 [1] is often consulted for guidance on this and many other matters relevant to seismic design.

In a SECED meeting (24th November 2004, 'Selection of Earthquake Time Histories for Analysis of Structures') Chris Rogers (CREA Consultants Ltd.) noted the requirements of ASCE 4-98 in relation to the time histories for seismic design. One of the requirements is that when responses from three components of motion are calculated simultaneously on a time history basis, the input motions in the

three orthogonal directions are to be statistically independent. ASCE 4-98 says two time histories can be considered statistically independent if the absolute value of the correlation coefficient is no more than 0.3. These requirements are varied for structures sensitive to long period motions, such as base isolated structures.

This note takes a look at the correlation to be found in some real earthquake records and compares the values found with the ASCE 4-98 limit. The real earthquake records examined were 12 records in the European Strong Motion Database [2] having a maximum horizontal acceleration roughly comparable to that often used in the UK for design of modern nuclear facilities, i.e. 0.25g. The histories considered are listed in the Appendix below.

Correlation is measured by a coefficient which ranges from 0 (uncorrelated, no statistical dependence) to 1 (completely correlated, identical) and is calculated

by the relation indicated in the commentary contained in ASCE 4-98:

$$\rho_{12} = \frac{E(x_1 - m_1)(x_2 - m_2)}{s_1 s_2}$$

where

E is the mathematical expectation, m_1, m_2 are the mean values of the histories x_1, x_2 and s_1, s_2 are the standard deviations of x_1, x_2 . The Mathcad [3] function *corr* was used to compute the correlation results presented below.

Figure 1 shows the correlation between the horizontal components of the 12 events. These are the correlations of the corrected records from the database and the figure shows that nearly half of the events, as recorded, don't satisfy the ASCE 4-98 correlation criteria.

What happens to the correlation value when the motion that occurred in the

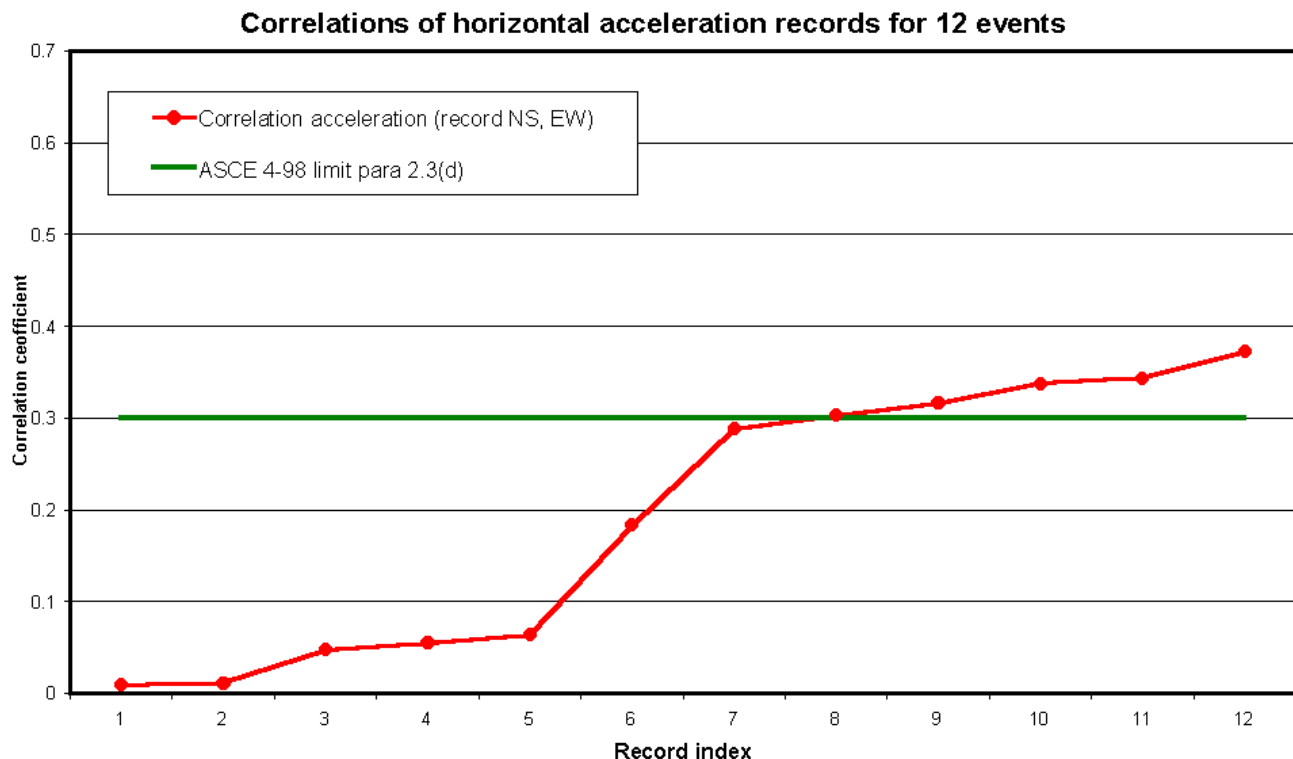

Figure 1 : Correlation of horizontal records

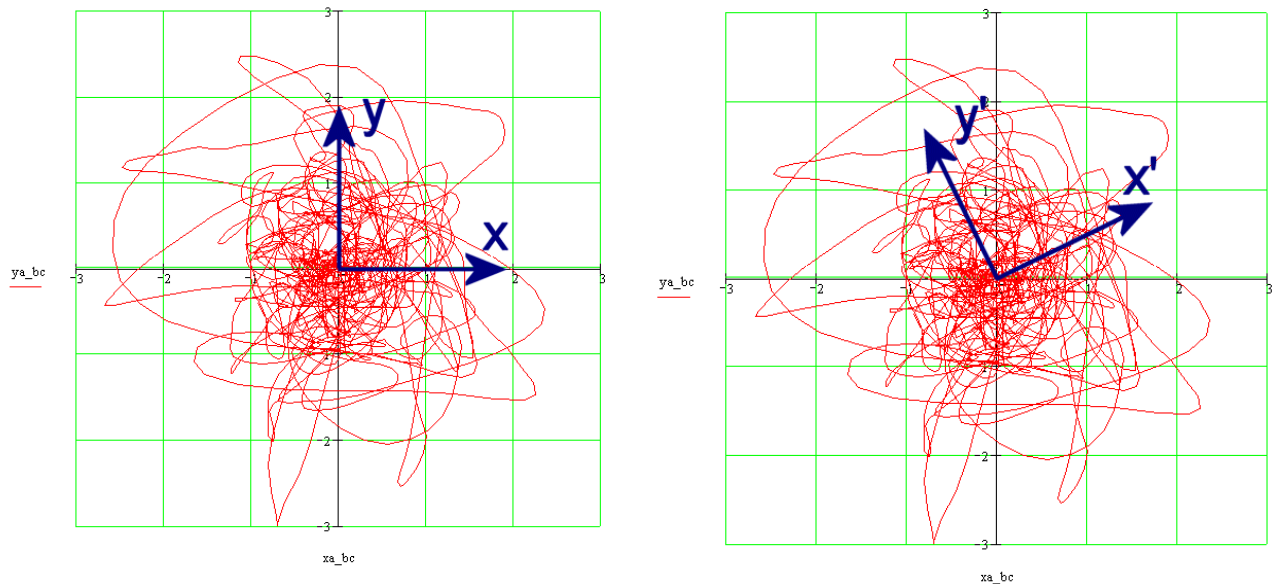

Figure 2 : Motion described by original and rotated axis systems

real event is described by axes rotated from the original ? Figure 2 shows the locus of the acceleration of a typical event of the 12 considered described by the original axes (left pane), and exactly the same motion described by a rotated axis set (right pane). Since

only the horizontal record components are being considered, the axes are rotated about the vertical direction.

Figure 3 shows the mean value of the correlation coefficient obtained by considering each possible rotated axis

direction. This shows that without changing the actual motion, the horizontal components from the real event can be configured to give a correlation less than the ASCE 4-98 limit. The maximum correlation is also shown on Figure 3. Again nearly half

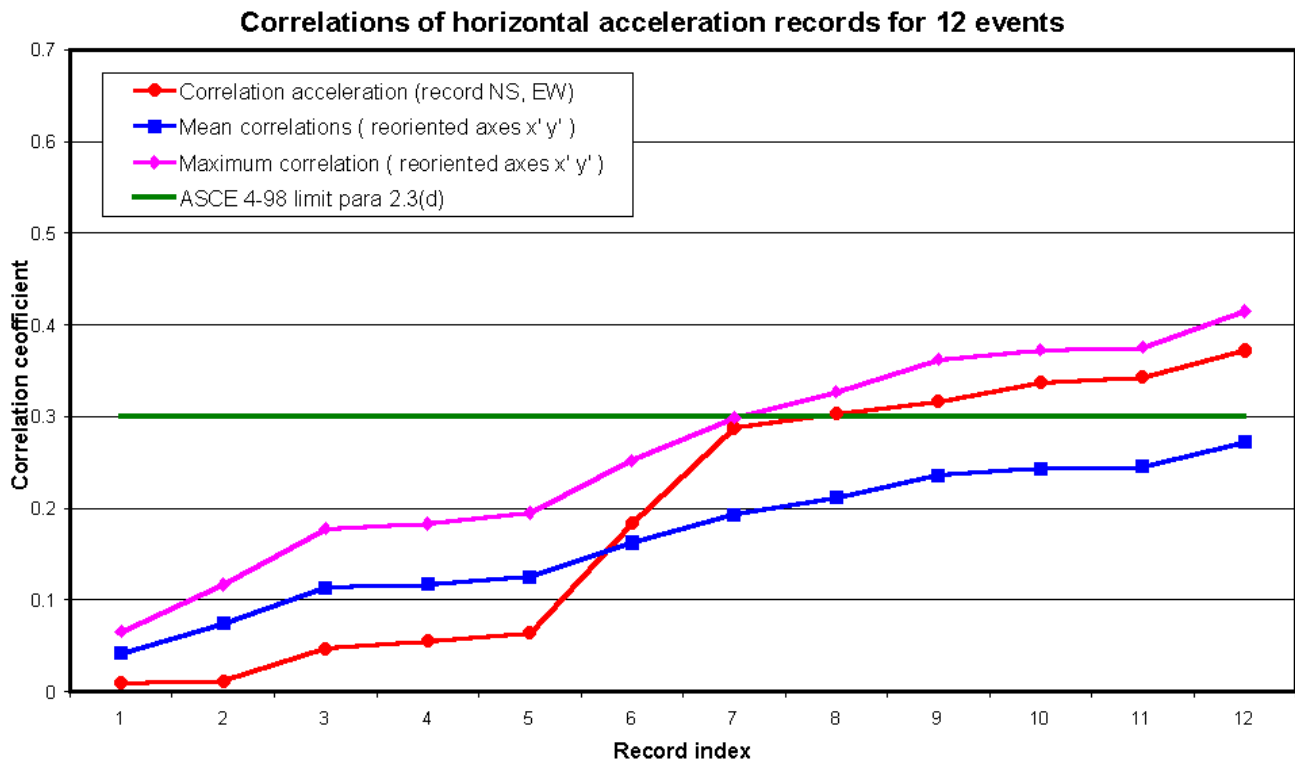

Figure 3 : Mean and maximum correlation with rotated axis system

Correlations of horizontal displacement records for 12 events

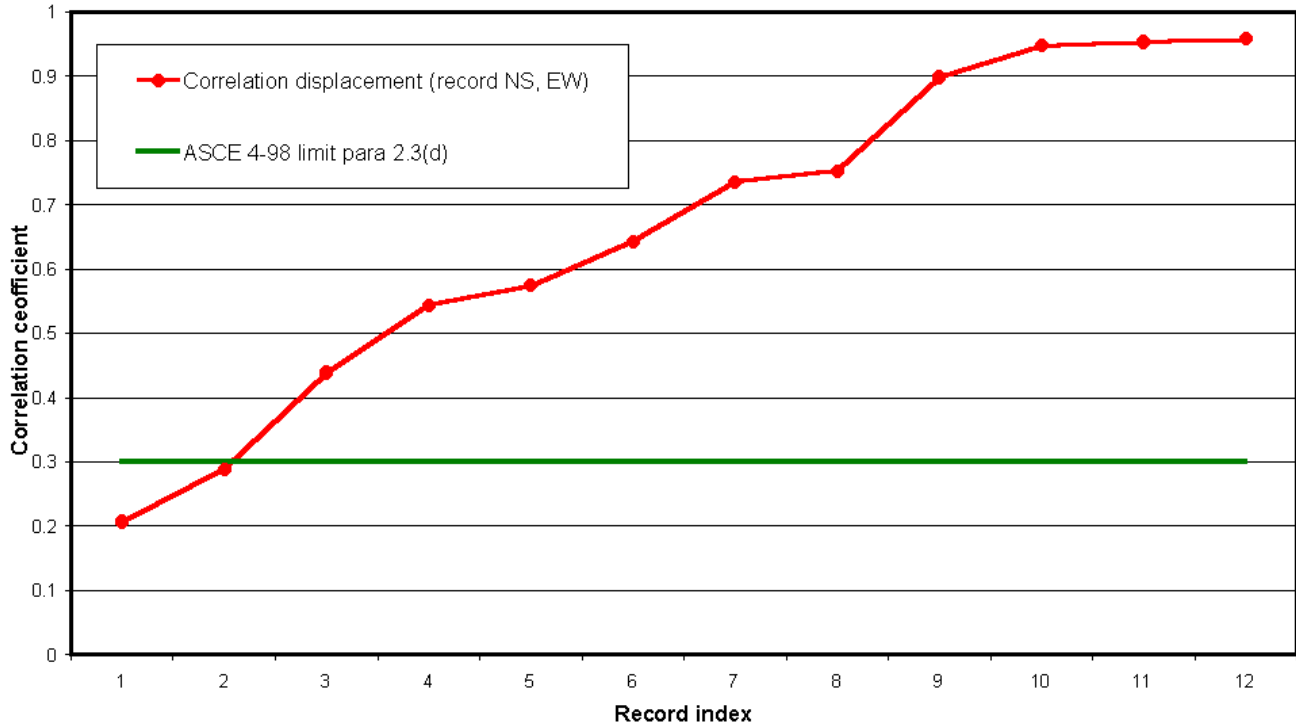

Figure 4 : Correlation of horizontal displacements

Correlations of acceleration records for 12 events

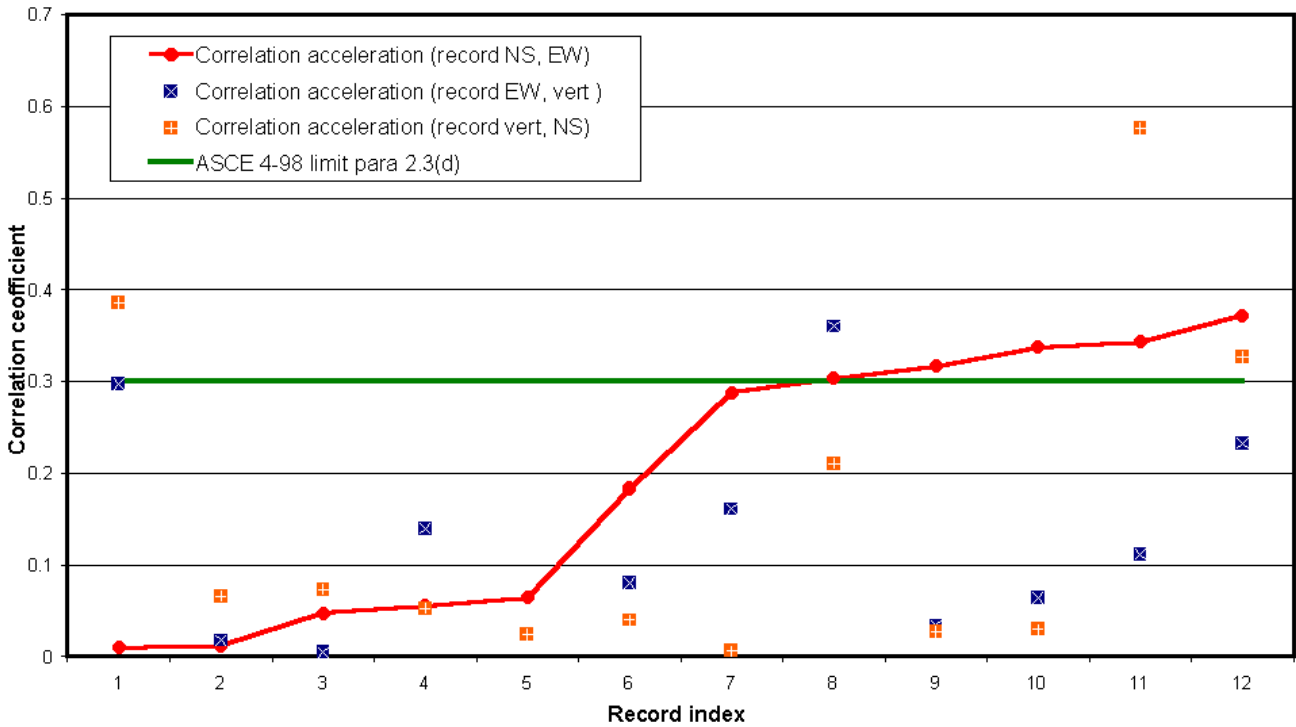

Figure 5 : Correlation of horizontal and vertical accelerograms

of the records show correlations greater than the ASCE 4-98 limit.

Thus it would appear that if you want to use the motion from a particular event and want to satisfy the correlation limit as stated, just rotate the axes. On the other hand should one choose only histories that satisfy the limit for all possible orientations of axes? Another alternative view would be to consider the ASCE 4-98 limit unrealistic since real event motions are often somewhat correlated when using the ASCE 4-98 statistical independence measure.

Figure 4 shows the correlation of the displacements derived from the real event accelerograms. Again the motion is not changed in any way, only the way the motion is viewed. If one considers the 0.3 value noted in ASCE 4-98 as the maximum correlation coefficient denoting uncorrelated records, this view clearly indicates that the records are often statistically correlated.

A final view of real event time history correlations is given in Figure 5 which shows the correlations between both horizontal and vertical records, in the as-recorded orientations. Here half the events have records which ASCE 4-98

would consider correlated. The amount of correlation is sometimes surprisingly large with large variations between the correlation values for different pairs of directions.

Conclusions

This brief look at real events records correlation and ASCE 4-98 indicates that for the motion applied to structures in design to be most like those experienced by structures in real events, the statistical independence requirements of ASCE 4-98 should not be too rigorously applied. On the other hand it should be readily possible to configure the histories applied in each coordinate direction in a design calculation to satisfy the ASCE 4-98 statistical independence requirement without actually changing the motion experienced by the structure at all. Finally if one chooses to interpret the ASCE 4-98 statistical independence of time histories requirement to apply to displacement histories (displacement histories typically being the form of motion history actually applied to numerical analysis models), then it will be noticeably more difficult to satisfy the ASCE 4-98 limit than if you choose to interpret the requirement as applying to accelerograms.

References

1. Seismic Analysis of Safety-Related Nuclear Structures and Commentary, American Society of Civil Engineers, ASCE 4-98, 2000, ISBN 0-7844-0433-X.
2. Ambraseys N., P. Smit, R. Berardi, D. Rinaldis, F. Cotton and C. Berge-Thierry (2000); Dissemination of European Strong-Motion Data CD-ROM collection, European Council, Environment and Climate Research Programme.
3. Mathcad Professional, Mathsoft Engineering and Education Inc.

Dr. Ian R. Morris

Engineering Simulation,
Modelling and Environmental
Management,
Nexia Solutions,
a subsidiary of British Nuclear Fuels.

Appendix: Records Used

The records used match the database search criteria for epicentral and fault distances less than 20km and horizontal accelerations in the range 2.5 to 25m/s².

Event	Magnitude	Station	Time	Database history no.
Ancona	4.55 Ms	Genio-Civile	1972/06/14 18:55:53.000	000027
Ancona	4.55 Ms	Ancona-Rocca	1972/06/14 18:55:53.000	000029
Denizli	5.1 Ms	Denizli-Bayindirlik ve Iskan Mudurlugu	1976/08/19 01:12:40.000	000105
Dinar	6.07 Ms	Dinar-Meteoroloji Mudurlugu	1995/10/01 15:57:13.000	000879
Erzincan	6.75 Ms	Erzincan-Meteorologij Mudurlugu	1992/03/13 17:18:40.000	000535
Friuli (aftershock)	6.06 Ms	Breginj-Fabrika IGLI	1976/09/15 03:15:19.000	000126
Friuli (aftershock)	5.98 Ms	Forgaria-Cornio	1976/09/15 09:21:19.000	000146
Montenegro	7.04 Ms	Bar-Skupstina Opstine	1979/04/15 06:19:41.000	000199
Tabas	7.33 Ms	Dayhook	1978/09/16 15:35:57.000	000182
Umbro-Marchigiano	5.5 Ms	Colfiorito	1997/09/26 00:33:16.000	000591
Umbro-Marchigiano	5.5 Ms	Nocera Umbra	1997/09/26 00:33:16.000	000593
Umbro-Marchigiano	5.9 Ms	Nocera Umbra	1997/09/26 09:40:30.000	000594

Bob Park – A Personal Note

In memory of Professor Bob Park who passed away on November 3, 2004 at the age of 71 in Christchurch, New Zealand.

Bob Park came to Bristol in 1960 to carry out research in concrete structures, his choice being determined by the recommendation of his University of Christchurch professor, who had been a colleague of Sir Alfred Pugsley during the 1940's. It may have appeared to be a strange choice because Bristol had neither experience of, nor special facilities for, such research but Pugsley had a proven record of transforming enthusiastic and competent young researchers into international experts, and Bob was no exception. It is an oft-repeated story, but possibly apocryphal, that Bob caused consternation in the conventional administration at Bristol by declaring in his application to be a Fijian national – his father having been a Medical Officer there – and the story has it that a photograph was called for before he could be accepted. Bob himself enjoyed telling this story!

Bob's ambition to succeed professionally was apparent even at this stage, because not only had he left a familiar environment for an unknown one but he had done so with his wife, Kathy, and their three small children. His knowledge of concrete structures was already broadly-based on arrival in Bristol and consequently he was quickly involved in undergraduate teaching and laboratory work. Despite this additional load, his PhD thesis on "Ultimate Strength of Uniformly Loaded Laterally Restrained Rectangular 2-Way Concrete Slabs" was approved in 1964.

By this time Bob and Kathy had two more children to cope with, but he still found time to play a full part in university life. Like most New Zealanders he was enthusiastic about sport, particularly rugby and cricket. He was a keen spectator rather than an active participant in the former, but in playing cricket his enthusiasm was inversely proportional to his skill; in fact he invented the method – now current – of stopping a ball crossing the boundary by diving on it and his batting had its origins in baseball!

I worked closely with Bob during 1961 – 64, on a consulting job involving the writing of a computer programme for the design and manufacture of pre-stressed double-tee concrete beams. I learned sufficient from him about concrete structures to be able to teach the rudiments after he returned to New Zealand but, although I offered to guide him through the Algol language, I believe he saw it as something he could leave to others. Before he left, it was gratifying for both of us to see two multi-storey car parks constructed using our double-tees.

It is possible that Bob would have stayed in Bristol but, like a contemporary and friend who became equally famous in wind engineering (Alan Davenport), he found that Professor Pugsley was not minded to invest in – or, as he (Pugsley) would have put it, to have his research constrained by - large experimental facilities. Until this time, Bob had not been interested in the dynamic properties of concrete, let alone earthquake engineering. I believe that his wife's wish to return to New Zealand, coupled with an offer from Christchurch to fund a cyclic loading testing machine if he returned, opened up for him a field of research which eventually made him internationally famous. Be that as it may, whilst in Bristol he designed such a testing machine to suit his needs, to be manufactured by the UK firm DARTEC and shipped to follow him on his return home in 1965. His use of this machine to probe the seismic behaviour of reinforced concrete beam-column joints, coupled with an ability to present his research in a clear and concise manner, led to his status as an international expert, partly expressing itself in his involvement in a number of code-drafting committees throughout the world.

Bob returned to Bristol whenever he could during his subsequent travels: he liked the place and we liked him. We were aware of considerable ill-health on two separate occasions, one of them caused by physical damage whilst jogging and subsequent errors by the medical profession, but he never lost his zest for life and was always the best of company. He rallied after Kathy's death, but never came to Bristol again.

Roy Severn

NOTABLE EARTHQUAKES JANUARY - JUNE 2005

Reported by British Geological Survey

YEAR	DAY	MON	TIME UTC	LAT	LON	DEP KM	MAGNITUDES ML MB MS	LOCATION
2005	10	JAN	18:47	37.10N	54.57E	32	5.3 5.1	NORTHERN IRAN At least 110 people were injured in the Gorgan area.
2005	20	JAN	22:13	56.49N	4.38W	5	2.7	KILLIN,CENTRAL Felt with maximum intensities of 4 EMS.
2005	25	JAN	16:44	37.62N	43.70E	41	5.3 5.6	TURKEY-IRAQ At least 2 people were killed, 22 people were injured and 80 buildings were damaged in the Hakkari area.
2005	5	FEB	12:23	5.29N	123.34E	525	6.4	CELEBES SEA Two people were killed.
2005	14	FEB	18:44	53.25N	3.88W	10	3.3	COLWYN BAY,WALES Felt with maximum intensities of 4 EMS.
2005	14	FEB	23:38	41.73N	79.44E	22	6.1 6.2	XINJIANG,CHINA At least 6,000 homes were destroyed or damaged in the Wushi area.
2005	22	FEB	02:25	30.74N	56.83E	14	6 6.5	CENTRAL IRAN At least 612 people were killed and 1,411 people were injured. An estimated 8,000 homes were damaged or destroyed in the Zarand area.
2005	2	MAR	10:42	6.53S	129.93E	202	7	BANDA SEA
2005	12	MAR	07:36	39.44N	40.98E	11	5.4 5	EASTERN TURKEY At least 16 people were injured.
2005	14	MAR	01:55	39.54N	40.89E	5	5.5 5.7	EASTERN TURKEY At least 18 people were injured.
2005	20	MAR	01:53	33.81N	130.13E	10	6.7	KYUSHU,JAPAN One person was killed and at least 500 people were injured.
2005	28	MAR	16:09	2.10N	97.11E	30	7.2	NORTHERN SUMATRA At least 1,000 people were killed and 300 people were injured.
2005	19	APR	21:11	33.64N	130.18E	19	5.3	KYUSHU,JAPAN At least 58 people were injured and 279 buildings were damaged or destroyed.
2005	3	MAY	07:21	33.71N	48.69E	12	4.9	WESTERN IRAN At least 4 people were killed, 26 people were injured and extensive damage occurred in the Borujerd area.
2005	6	JUN	07:41	39.22N	41.10E	10	5 5.4	EASTERN TURKEY Approximately 50 people were injured, several buildings collapsed and numerous buildings were damaged.
2005	8	JUN	01:21	53.03N	2.20W	3	2.6	STOKE-ON-TRENT Felt with maximum intensities of 4 EMS.
2005	13	JUN	22:44	19.96S	69.11W	116	6.8	TARAPACA,CHILE Eleven people were killed and at least 200 people were injured.
2005	15	JUN	02:50	41.29N	125.97W	10	7.2MW	N CALIFORNIA

Issued by: Bennett Simpson, British Geological Survey, July 2005.

Non British Earthquake Data supplied by: The United States Geological Survey

Forthcoming Events

28 September 2005

Seismic Vulnerability of a Housing Project
ICE 6.00pm

26 October 2005

Seismic Geology
ICE 6.00pm

30 November 2005

Blast
ICE 6.00pm

SECED Newsletter

The SECED Newsletter is published quarterly. Contributions are welcome and manuscripts should be sent on a PC compatible disk or directly by Email. Diagrams, pictures and text should be in separate electronic files.

Copy typed on paper is also acceptable. Diagrams should be sharply defined and prepared in a form suitable for direct reproduction. Photographs should be high quality (black and white prints are preferred). Diagrams and photographs are only returned to the authors on request.

Articles should be sent to:

John Sawyer,
Editor SECED Newsletter,
c/o The Secretary,
SECED,
Institution of Civil Engineers,
Great George Street,
London
SW1P 3AA, UK.

Email: john.sawyer@projectservices.com

SECED

SECED, The Society for Earthquake and Civil Engineering Dynamics, is the UK national section of the International and European Associations for Earthquake Engineering and is an affiliated society of the Institution of Civil Engineers.

It is also sponsored by the Institution of Mechanical Engineers, the Institution of Structural Engineers, and the Geological Society. The Society is also closely associated with the UK Earthquake Engineering Field Investigation Team. The objective of the Society is to promote co-operation in the advancement of knowledge in the fields of earthquake engineering and civil engineering dynamics including blast, impact and other vibration problems.

For further information about SECED contact:

The Secretary,
SECED,
Institution of Civil Engineers,
Great George Street,
London SW1P 3AA, UK.

SECED Website

Visit the SECED website which can be found at <http://www.seced.org.uk> for additional information and links to items that will be of interest to SECED members.

Email: webmaster@seced.org.uk